



A Tsurumi Pump Company

# PRODUCT DATA SHEET

DRG DRAINAGE

ZEN-DRG1000/2/80HA0FTEX | 807388



IMAGE INDICATIVE ONLY

## PRODUCT DETAILS

Suitable for use in applications that have unstrained soiled biological wastewaters and sewage and also for civil lifting applications. The DRG can be used in wastewater treatment plants, sewer systems, livestock farms, industry and agriculture.

Cast-iron construction with 2 opposed silicon carbide mechanical seals in an inspectable oil sump, anticlogging system. Includes a 10m cable.

## APPLICATIONS

The DRG features a cast-iron, open-channel impeller with large free-passage solids handling, designed for the recirculation of industrial and process waters, civil drainage lifting stations, and the drainage and recovery of first-flush storm-water. Suitable for heavy-duty professional and industrial use.

## FEATURES

- Cast-iron body, impeller and flange EN-GJL250
- AISI 431 motor shaft
- 2-pole, 3-phase motor
- Class H insulation [180°C]
- IP68 protection
- Thermal protections integrated into the stator
- Moisture detection probe fitted to mechanical seal oil chamber
- Two-component epoxy painting 150µm
- Two silicon carbide mechanical seals [SiC] inside the oil chamber
- Cable length 10m

## TECHNICAL DATA

<b>RATED POWER P1 / P2</b>	8.5kW / 7.5kW
<b>MAX. FLOW [Q]</b>	45.1 L/sec
<b>MAX. HEAD [M]</b>	34.9 m
<b>MOTOR INSULATION</b>	H Class
<b>PROTECTION CLASS</b>	IP68
<b>MOTOR PROTECTION</b>	Thermal protection and moisture detection
<b>MOTOR DUTY</b>	Continuous Use S1
<b>MAX. LIQUID TEMPERATURE</b>	40°C
<b>MECHANICAL SEAL</b>	Dual Silicon Carbide
<b>MAX. DENSITY AND PH</b>	1.100 kg/m <sup>3</sup>   pH 6 – 14

<b>RATED VOLTAGE</b>	400V 3ph 50Hz
<b>MOTOR POLES</b>	2-pole
<b>CURRENT</b>	Rated FLC 13.7A DOL current 92.1A
<b>POWER CABLE TYPE</b>	10m H07RN-F Cable
<b>MAX. HYDRAULIC EFFICIENCY</b>	64.2%
<b>FREE PASSAGE</b>	40 mm
<b>IMPELLER TYPE</b>	Open-channel impeller
<b>SUCTION</b>	DN80
<b>OUTLET</b>	DN80
<b>WEIGHT (KG)</b>	79.2 kg (pump only)

## CURVE

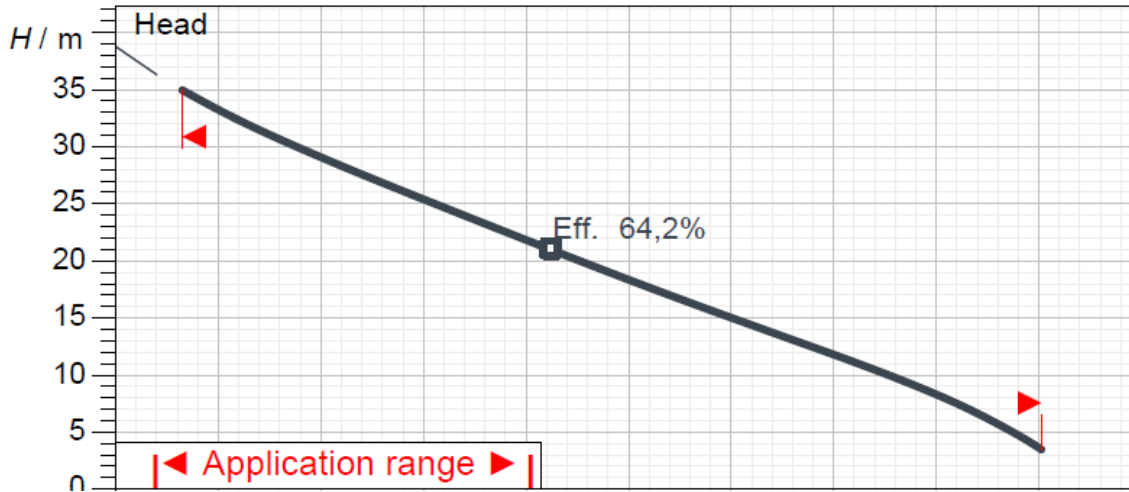

## DIMENSIONS

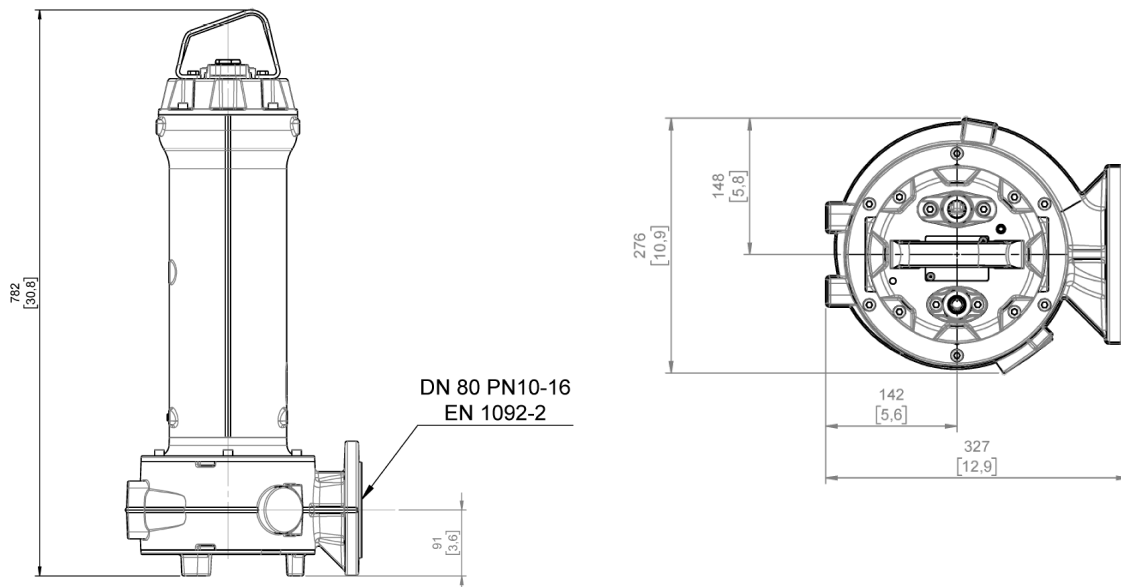

## WARRANTY / CERTIFICATIONS

